

Grosime Sticlă

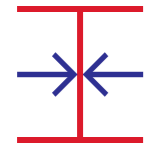

22 - 48 mm

Etanșeitate la apă

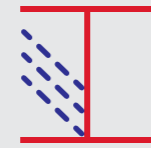

Clasa 8A

Permabilitate la aer

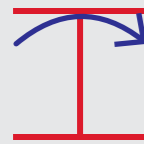

Clasa 3

Resistența la vânt

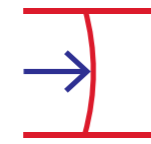

Clasa C3

Coefficientul de atenuare fonică

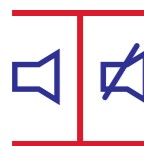

Rw = 35dB

Coefficient de transfer termic

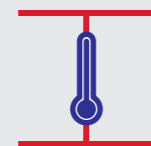

2.4 - 6.2 W/(m<sup>2</sup> K)

**EXALCO**<sup>®</sup>  
ALUMINIUM SYSTEMS

[www.exalco.ro](http://www.exalco.ro)

# ALBIO 230

SISTEM GLISANT LIFT & SLIDE CU BARIERĂ TERMICĂ

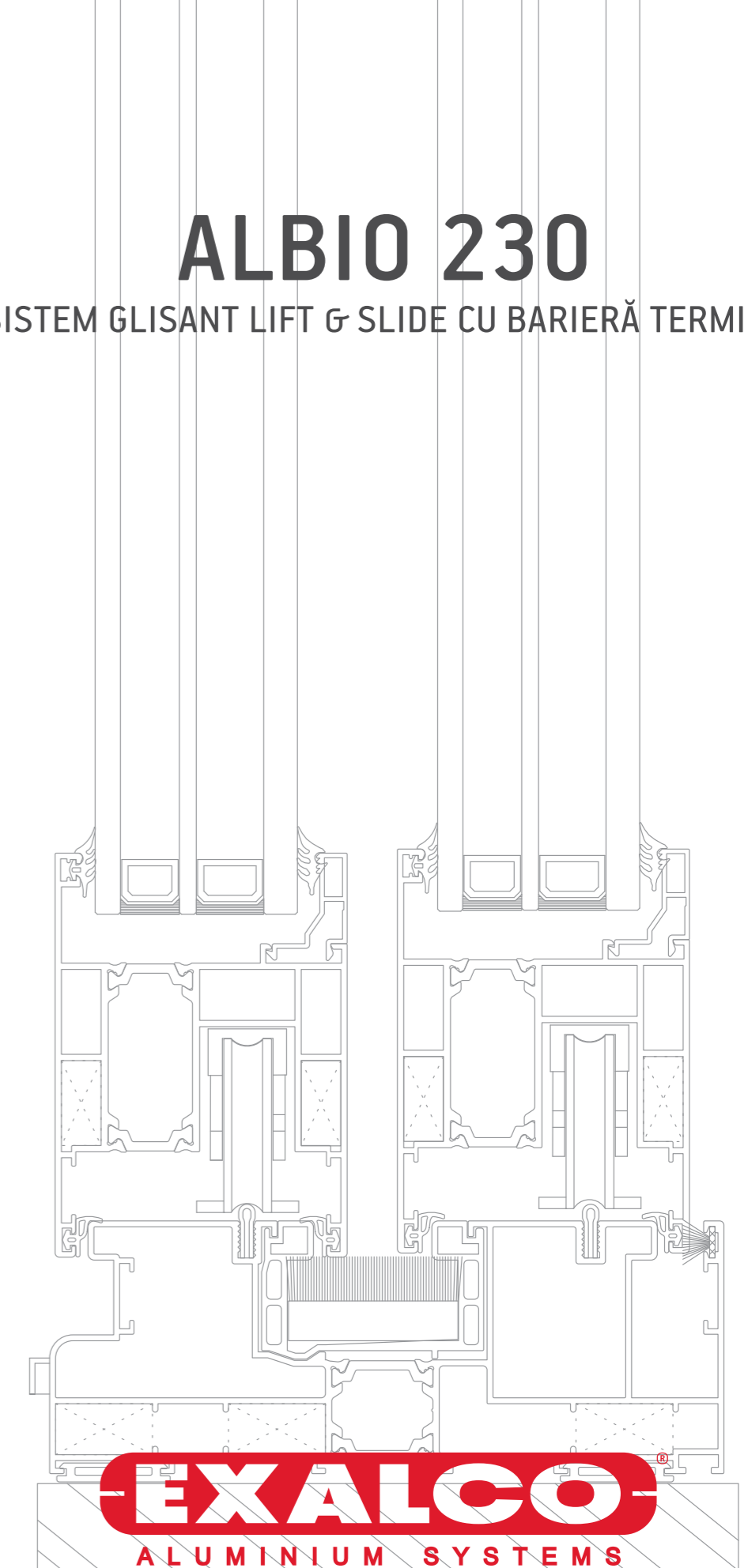



## Albio 230

### SISTEM GLISANT LIFT & SLIDE CU BARIERĂ TERMICĂ

Albio 230 este un sistem de glisare cu ridicare, adecvat pentru o greutate a cercevei de până la 400 kg, cu un mecanism special integrat de rulare tip Lift & Slide (Hebe-Schiebe) și o excelentă tehnologie de izolare termică, asigurată de poliamide și profile multicamerale de PVC.

Sistemul este proiectat pentru a satisface o mare varietate de cerințe funcționale, estetice și în plus respectarea celor mai înalte standarde de construcție și de eficiență energetică.

